

**United States Department of the Interior
Heritage Conservation and Recreation Service**

**National Register of Historic Places
Inventory—Nomination Form**

For HCRS use only

received _____

date entered _____

See instructions in *How to Complete National Register Forms*
Type all entries—complete applicable sections

1. Name

historic Wheeling Historic District

and/or common Wheeling Central Business District

2. Location

street & number See Continuation Sheet _____ not for publication

city, town Wheeling _____ vicinity of _____ congressional district First

state West Virginia code 54 county Ohio code 069

3. Classification

Category	Ownership	Status	Present Use
<input checked="" type="checkbox"/> district	<input type="checkbox"/> public	<input checked="" type="checkbox"/> occupied	<input type="checkbox"/> agriculture
<input type="checkbox"/> building(s)	<input type="checkbox"/> private	<input type="checkbox"/> unoccupied	<input checked="" type="checkbox"/> commercial
<input type="checkbox"/> structure	<input checked="" type="checkbox"/> both	<input type="checkbox"/> work in progress	<input type="checkbox"/> educational
<input type="checkbox"/> site	Public Acquisition	Accessible	<input checked="" type="checkbox"/> entertainment
<input type="checkbox"/> object	<input type="checkbox"/> in process	<input type="checkbox"/> yes: restricted	<input checked="" type="checkbox"/> government
	<input type="checkbox"/> being considered	<input checked="" type="checkbox"/> yes: unrestricted	<input type="checkbox"/> industrial
		<input type="checkbox"/> no	<input type="checkbox"/> military
			<input type="checkbox"/> museum
			<input type="checkbox"/> park
			<input checked="" type="checkbox"/> private residence
			<input checked="" type="checkbox"/> religious
			<input type="checkbox"/> scientific
			<input type="checkbox"/> transportation
			<input type="checkbox"/> other:

4. Owner of Property

name Multiple Ownership

street & number _____

city, town _____ vicinity of _____ state _____

5. Location of Legal Description

courthouse, registry of deeds, etc. Ohio County Courthouse

street & number 15th and Chapline Streets

city, town Wheeling state West Virginia 26003

6. Representation in Existing Surveys

title Wheeling, West Virginia, Central Business District: An Architectural Inventory has this property been determined eligible? yes no

date 1978 federal state county local

depository for survey records Friends of Wheeling, Inc.

city, town Wheeling state West Virginia 26003

UNITED STATES DEPARTMENT OF THE INTERIOR
HERITAGE CONSERVATION AND RECREATION SERVICE

FOR HCRS USE ONLY

RECEIVED

DATE ENTERED

**NATIONAL REGISTER OF HISTORIC PLACES
INVENTORY -- NOMINATION FORM**

Wheeling Historic District, Wheeling, Ohio County, West Virginia

CONTINUATION SHEET Location ITEM NUMBER 2 PAGE 2

West side of Eoff St. between 12th and 15th Sts.

East side of Chapline St. between 12th and 15th Sts.

West side of Chapline St. between 11th St. and B.&O. Railroad Elevated Tracks

East side of Market St. between Bridge St. Alley and B.&O. Railroad Elevated Tracks

West side of Market St. between 10th St. and B.&O. Railroad Elevated Tracks

East side of Main St. between 10th St. and 16th Sts.

West side of Main St. between 10th St. and 16th Sts.

East side of Water St. between 11th and 14th Sts.

South side of 10th St. between Ohio River and Market St.

North side of 11th St. between Water St. and Alley between Market and Chapline Sts.

South side of 11th St. between Water and Chapline Sts.

North side of 12th St. between Water and Chapline Sts.

South side of 12th St. between Water and Eoff Sts.

North side of 14th St. between Water and Eoff Sts.

South side of 14th St. between Main and Eoff Sts.

North side of 15th St. between Chapline and Eoff Sts.

North side of 16th St. between Main and Chapline Sts.

South side of 16th St. between Main and Chapline Sts. including South St.

Between 16th St. and B.&O. Railroad Elevated Tracks

13th St. Alley between Eoff and Chapline Sts.

15th St. Alley between Chapline and Market Sts.

7. Description

Condition		Check one	Check one
<input type="checkbox"/> excellent	<input type="checkbox"/> deteriorated	<input type="checkbox"/> unaltered	<input checked="" type="checkbox"/> original site
<input checked="" type="checkbox"/> good	<input type="checkbox"/> ruins	<input checked="" type="checkbox"/> altered	<input type="checkbox"/> moved date _____
<input type="checkbox"/> fair	<input type="checkbox"/> unexposed		

Describe the present and original (if known) physical appearance

The Wheeling Historic District contains approximately 260 buildings, the majority of which are of architectural or historical significance and is the site of the original location of Fort Henry. The District is situated at the base of Wheeling Hill between Wheeling Creek and the Ohio River, and the buildings are representative of styles from the early 19th century to the present. While the earlier buildings within the District are generally only several stories tall with Greek Revival and/or Italiante decoration, the buildings of later periods become proportionally taller with the years at the end of the 19th century and into the early 20th with styles more closely reflecting Romantic Revivals and the Picturesque to the Neo-Classical designs of the Ecole des Beaux-Arts of the early 20th century. The majority of buildings are of brick and sandstone masonry structuring, but facade applique of stone, marble, and cast iron are also prevalent in reflecting period design. Being largely urban in density, many buildings are of the row type design with several sharing common halls.

The District is largely commercial in character even as it was in the early and mid-19th century when many buildings contained shops on the ground levels and storage or apartments on the upper levels. However, it was during the second half of the 19th century and the early 20th that it became a dense urban commercial center with major modes of transportation terminating there and becoming surrounded by residential neighborhoods as it is still today. There are several major townhouse residences located within the fringe of the District, but they have all been converted for commercial purposes. Although buildings within the District are all largely in good structural condition, facade alterations occurring mainly in the 1950's and 1960's are in evidence on many of the commercial buildings. However, these alterations are basically limited to the street level of most of the buildings leaving the upper story levels in nearly original conditions, some alterations have taken the form of aluminum panels covering the entire facade. Yet evidence exists that behind many of these additions the original elevations survive.

Attempts at renovation and rehabilitation have begun within the District largely limited to the shops on Market Street facing a new plaza which was originally the location of the town markets. The Baltimore and Ohio Passenger Terminal has also been renovated with the original Custom House, now referred to as West Virginia Independence Hall, being the only restoration within the District. Major churches supporting the community are also within the District, and although somewhat slightly altered in some cases, still largely retain their stylistic ambience and pivotal importance with their towers dominating streetscapes. As for historic archeological potential, the original location of Ft. Henry is debated, however, unfortunately heavy urban development renders any potential as almost nil.

BUILDINGS OF NATIONAL, MAJOR, AND PIVOTAL SIGNIFICANCE:

1. United States Custom House, 1859, S.E. corner of 16th and Market Sts. Sandstone and brick construction, three-story Italian Revival governmental building. Originally U. S. Custom House, Courthouse, and Post Office, Ammi B. Young, Architect. Site of meeting of citizens to annual Articles of Secession for Virginia and Declaration of Independent Restored Government of Virginia in 1861 with ultimate statehood following in 1863. Listed in the National Register of Historic Places.

UNITED STATES DEPARTMENT OF THE INTERIOR
HERITAGE CONSERVATION AND RECREATION SERVICE

FOR HCRS USE ONLY

RECEIVED

DATE ENTERED

**NATIONAL REGISTER OF HISTORIC PLACES
INVENTORY -- NOMINATION FORM**

Wheeling Historic District, Wheeling, Ohio County, West Virginia

CONTINUATION SHEET Description ITEM NUMBER 7 PAGE 2

2. Linsley Institute, 1859. 1413 Eoff St. Military Academy altered to medical clinic. Italian Revival styling altered with later Renaissance Revival detailing. (Henry Coen, Architect) Site of first capitol of West Virginia.
3. United States Court House, Custom House, and Post Office, 1905, 2501 Chapline St. Neo-Classical Beaux-Arts design building. (Marsh & Peter, Architects).
4. St. Matthew's Church - Strider House, c.1892, 1410 Chapline St. Brick church and parish house with stone facade in Gothic Romantic Revival styling.
5. John Frissell House, 1835, 54 14th St. 2 Story Greek Revival residence altered to medical clinic with Italianate Cornice detailing.
6. Absalom Ridgeley Residence, 1838, 58 14th St. Brick Greek Revival house altered to commercial offices with Italianate Cornice detailing.
7. Thomas Paull -George Paull House, 1840, 1865. 57 14th St. Two-story brick residence altered to commercial offices and possessing Italianate detailing from its second period of construction.
8. James Fitzsimmons Residence, c.1850, 1324 Chapline St. Classical Revival townhouse altered in 1890 to its present heavy Neo-Classical styling as a private club.
9. Thomas Paull House, c.1835, 1314 Chapline St. Brick Greek Revival townhouse of prominent merchant family altered to a funeral home.
10. Lynda Spidel House, c.1880, 1308 Chapline St. Brick Victorian Neo-Classical residence altered to a funeral home.
11. J. W. Paxton Residence, c.1885, 1300 Chapline St. Two-story brick Victorian townhouse with Neo-Classical detailing altered to civic facilities.
12. Baltimore and Ohio Passenger Terminal, 1907-08, College Square (M. A. Long, Architect), Renaissance Revival Beaux-Arts building altered to West Virginia Northern Community College that together with its elevated railway tracks to its rear create a major pivotal structure and end terminus at the southern end of the District. Listed in the National Register of Historic Places.
13. English Lutheran Church, 1897, 35 16th St. Brick and stone Victorian-Romanesque Revival Church. (Franzheim, Giesey & Faris, Architects)

FOR HCRS USE ONLY

RECEIVED

DATE ENTERED

**NATIONAL REGISTER OF HISTORIC PLACES
INVENTORY -- NOMINATION FORM**

Wheeling Historic District, Wheeling, Ohio County, West Virginia

CONTINUATION SHEET Description ITEM NUMBER 7 PAGE 3

14. St. James Evangelical Lutheran Church, 1891, 1409 Chapline St. Brick construction building with stone facade in Romantic Revival Gothic detailing.
15. First United Presbyterian Church, 1825, 1301 Chapline St. Brick and sandstone Greek Revival building with an Ionic portico being of particular note.
16. City Bank Building, c.1890, 1300 Market St. (Franzheim, Giesey, and Faris, Architects). Brick with stone facade multi-story commercial office building in turreted Romanesque styling.
17. Residence, c.1830, 68 12th St., Two-story brick building with exceptionally delicate Greek Revival proportioning and detailing.
18. Heiskell Building, c.1875, 1410 Main St. Brick four-story commercial building in Victorian style with cast iron pilastered detail.
19. List Building, c.1875, 1406 Main St. Three-story brick Victorian commercial building, originally wool dealers, presently used as storage, Classical cast iron pilaster detail, Sweeney and Co. Foundry, Wheeling, West Virginia. Later expansion addition to earlier List Buildings at the north wall.
20. List Building, c.1855, S.E. Corner Main & 14th Sts. Originally List, Davenport, and Parks, Wholesale Grocers and Pork Packers. Brick building with Italianate detail and cast iron pilaster ornament; Sweeney and Co. Foundry, Wheeling, Virginia.
21. Bank of Wheeling, 1892, 1229 Main St. (Franzheim, Giesey, and Faris, Architects). Stone facaded Romanesque Revival commercial building with heavy organic relief work.
22. W. M. Marsh - Wheeling Drug Co. Building, c.1915, S.W. Corner Main and 12th Sts. Multi-story office building of brick construction with painted terracotta facade in Eclectic styling with vaguely Classical overtones. (Charles W. Bates, Architect).
23. Samuel Ott Building, c.1855, 1208 Main St. Three-story brick commercial structure with Italianate detailing. Originally used as hardware and saddeler store.
24. Capitol Theatre, c.1926, 1015 Main St. Exceptional late Beaux-Arts design Vaudeville House and Theatre. Presently major country-western music theatre of national prominence that in itself constitutes a pivotal structure both architecturally as well as tourist and art oriented. (Charles W. Bates, Architect).
25. William Hogg Building, c.1840, 1060-68 Main St. Three-story brick Greek Revival commercial structure.

FOR HCRS USE ONLY

RECEIVED

DATE ENTERED

**NATIONAL REGISTER OF HISTORIC PLACES
INVENTORY -- NOMINATION FORM**

Wheeling Historic District, Wheeling, Ohio County, West Virginia

CONTINUATION SHEET Description ITEM NUMBER 7 PAGE 4

26. William Paxton - George Johnson Buildings, c.1835, 1061 Market St. Three-story brick Greek Revival commercial structure.
27. Market Plaza between 10th and 11th Sts. Original site of City Market.

BUILDINGS SIGNIFICANT AS CONTRIBUTING TO THE HISTORICAL/ARCHITECTURAL AMBIENCE OF THE ENTIRE DISTRICT:

1. Pythian Building, 1927, 30 16th St. Late Classical Revival Lodge in Renaissance/Beaux-Arts style with Mythological and Classical motif in frieze.
2. Eoff Building, c.1860, 34 16th St. Three-story brick Italianate rowhouse.
3. Eoff Building, c.1860, 36 16th St. Three-story brick Italianate rowhouse.
4. Eoff Building, c.1860, College Square, rear facade of rowhouse facing 16th St. altered.
5. Eoff Building, c.1860, College Square, rear facade of rowhouse facing 16th St. with metal Italianate cornice.
6. Breining Building, c.1896, 1619 Market St. Single story brick Victorian building.
7. Dieringer Building, c.1890, 1615 Market St. Four-story brick Victorian building.
8. Pabst Brewing Co. - Quarier Savings & Trust Co. Building, c.1900, 1920. 1601 Market St. Two buildings combined and modernized into a single bank.
9. Rice Building, 1926, 16 16th St. Four-story modern commercial structure.
10. Residence, c.1899,1901, 12-14 16th St. Built by James Paxton, three-story brick Neo-Classical structure.
11. Union Warehouse Holding Co. Building, c.1920, 2 16th St. Modern multi-story brick commercial structure.
12. Alexander Rogers - Margaret J. Lange/Residence, c.1890, 62 14th St. Victorian brick townhouse with applied Classical motifs.
13. Alexander Rogers - Margaret J. Lange/Residence, c.1890, 60 14th St. Victorian brick townhouse with geometric detail work.

UNITED STATES DEPARTMENT OF THE INTERIOR
HERITAGE CONSERVATION AND RECREATION SERVICE

FOR HCRS USE ONLY

RECEIVED

DATE ENTERED

**NATIONAL REGISTER OF HISTORIC PLACES
INVENTORY -- NOMINATION FORM**

Wheeling Historic District, Wheeling, Ohio County, West Virginia

CONTINUATION SHEET	Description	ITEM NUMBER	7	PAGE	5
14.	<u>Natural Gas of West Virginia Building</u> , c.1901, 1226 Chapline St. Two-story brick Neo-Classical office.				
15.	<u>Aul Building</u> , 1906, 1224 Chapline St. Three-story brick, Neo-Classical office.				
16.	<u>Margaret Lange House</u> , c.1890, 1206 Chapline St. Three-story Victorian townhouse.				
17.	<u>Board of Trade - Court Theatre</u> , 1900, S.E. Corner of 12th and Chapline Sts. Multi-story theatre/office building in Neo-Classical style (Edward B. Franzheim, Architect).				
18.	<u>Paull Building</u> , c.1920, 13th and Eoff Sts. Single-story brick structure with modern front.				
19.	<u>Storage Warehouse</u> , c.1920, 13th St. Alley, rear single-story structure to office building facing Eoff St.				
20.	<u>Carroll Club</u> , c.1900, 13th St. Alley, rear multi-story brick addition in vaguely Classical style to J. W. Paxton residence.				
21.	<u>Formosa Apartments</u> , c.1900, 1305-11 Eoff St. Four-story Neo-Classical apartment buildings built by Rev. John J. Kain and Rev. Patrick J. Donahue.				
22.	<u>Dr. John C. Hupp House</u> , c.1850, 1317-21 Eoff St. Two-story brick Italianate Lease residence.				
23.	<u>Dr. John C. Hupp House</u> , c.1850, 59 14th St. Three-story Victorian Lease residence.				
24.	<u>Dr. John C. Hupp House</u> , c.1889, 59 14th St. Three-story Victorian Lease residence with Classical detail.				
25.	<u>Bell Telephone Co.</u> , c.1910, 1501 Chapline St. Neo-Classical office building.				
26.	<u>Congress Hall</u> , c.1857, 1425 Chapline St. Two-story Italianate brick building with later Neo-Classical detail at entrance.				
27.	<u>Shop Building</u> , c.1920, 15th St. Alley. Two-story brick modern commercial structure with vague Classical planning.				
28.	<u>Wheeling Tent and Awning Co. Building</u> , c.1944, 1417 Chapline St. White glazed brick commercial structure.				

UNITED STATES DEPARTMENT OF THE INTERIOR
HERITAGE CONSERVATION AND RECREATION SERVICE

FOR HCRS USE ONLY
RECEIVED
DATE ENTERED

**NATIONAL REGISTER OF HISTORIC PLACES
INVENTORY -- NOMINATION FORM**

Wheeling Historic District, Wheeling, Ohio County, West Virginia

CONTINUATION SHEET Description ITEM NUMBER 7 PAGE 6

29. Dr. D. Baguley Residence, c.1850, 1413 Chapline St. Two-story brick Italianate structure.
30. Riley Building, 1920, N.W. corner 14th and Chapline Sts. Brick modern office building.
31. W. Arnetta Delaplaine Building, c.1870,1910(?), 1311 Chapline St. Three-story brick Neo-Classical structure.
32. German Fire Insurance Building, 1906, 1219 Chapline St. Two-story Neo-Classical, Georgian Revival brick commercial structure.
33. Commercial-Lodge Building, 1895,1910, 1121-19 Chapline St. Built by John Morris and Louis Stifel, Neo-Classical brick structure.
34. Commercial Building, c.1922, 1117 Chapline St. Callahan-Farris Building Co. office, Neo-Classical brick structure.
35. Residence, c.1850, 1111 Chapline St. Built by William and Alexander Paxton, Greek Revival three-story brick townhouse.
36. Residence, c.1850, 1109 Chapline St. Built by Jonathan Cooper and William Senseney, Classical Revival brick three-story townhouse.
37. Commercial Building, c.1890, S.E. Corner 11th and Market Sts. Built by Frederick Unruh - Emma Hoffman, two-story Victorian structure.
38. John McNell Building, c.1900, 57 11th St. Three-story Neo-Classical brick structure.
39. Civic Building, c.1900, 41 11th St. City of Wheeling original owners, three-story modernized Neo-Classical brick building.
40. Commercial Building, c.1860, 1066 Market St. Built by William Paxton, three-story modernized Italianate brick structure.
41. Commercial Building, c.1866, 1062 Market St. Built by John M. Garrella (basket maker) two-story Italianate structure.
42. Commercial Bank Building, 1919, 1054 Market St. Neo-Classical brick structure.
43. Henry Kalibitzer Building, c.1910, 1050 Market St. Neo-Classical commercial structure.

FOR HCRS USE ONLY

RECEIVED

DATE ENTERED

**NATIONAL REGISTER OF HISTORIC PLACES
INVENTORY -- NOMINATION FORM**

Wheeling Historic District, Wheeling, Ohio County, West Virginia

CONTINUATION SHEET Description ITEM NUMBER 7 PAGE 7

44. Central Business Association Building, c.1878, 1048 Market St. Three-story brick Italianate structure.
45. John Welty Building, c.1910, 1046 Market St. Neo-Classical grocery building.
46. Edward Larkin Building, c.1878, 1042 Market St. Three-story Victorian dry goods and notions store.
47. Commercial Structure, c.1870, 1920(?), 1038 Market St. Welty Estate Builders, grocery building modernized from three buildings to one.
48. Commercial Building, c.1890,1933, 18 10th St. James Hawley - T. S. Riley Developers. Two-story brick Victorian with later addition of modern facade.
49. Stone & Thomas Department Store, c.1921, Market Plaza. Multi-story modern commercial building.
50. Charles Feinler Building, c.1898, Bridge Street. Three-story brick Victorian structure.
51. Houser Building, c.1865, 1031 Market St. Two-story brick Italianate commercial structure.
52. Commercial Building, c.1860, 1033 Market St. Three-story brick Classical Revival structure.
53. Houser-Colvin Building, c.1865, 1037 Market St. Three-story brick Italianate structure.
54. Daniel List Building, c.1869, 1043-41 Market St. Three-story Italianate structure.
55. Nicholas Crawley Building, c.1870, 1055 Market St. Three-story brick Classical Revival structure.
56. Johnson-Folmar Building, c.1867, Market Plaza. Three-story brick Classical Revival structure.
57. T. L. Harris Building (Building Contractor) c.1910, 27 11th St. Three-story brick and wood frame Victorian structure.
58. Max Beuter Building, c.1895, 125 11th St. Four-story brick Victorian building. Originally wine and liquor store, saloon, and residence.

FOR HCRS USE ONLY

RECEIVED

DATE ENTERED

NATIONAL REGISTER OF HISTORIC PLACES INVENTORY -- NOMINATION FORM

Wheeling Historic District, Wheeling, Ohio County, West Virginia

CONTINUATION SHEET Description ITEM NUMBER 7 PAGE 8

59. Eleanor Johnston Building, c.1901-07, 23 11th St. Three-story brick Neo-Classical structure.
60. Eleanor Johnston Building, c.1901-07, 19 11th St. Three-story brick Neo-Classical structure.
61. Annie Gollmer Building, c.1893, 30 11th St. Three-story brick Victorian, baskets-fancy goods store/residence.
62. Alfred Egeter Building, c.1895, 1107 Market St. Neo-Classical Revival/Romanesque stone commercial structure (Franzhiem, Giesey & Faris, Architects).
63. Joseph Deville (Stenographer) Building, c.1905, 20 Bridge St. Two-story brick Neo-Classical structure.
64. Eleanor Johnston Building, c.1901-07, 15-17 11th St. Two-story brick Neo-Classical structure.
65. Christian Hess Building, c.1880, 1115 Market St. Two-story modernized department store.
66. Welty Building, c.1890, 1121 Market St. Multi-story brick Victorian commercial structure.
67. Framzheim - Bertschy Building, c.1907(?), 1133 Market St. Modern commercial structure.
68. S. S. Kresge Building, c.1922(?), 1135 Market St. Modern commercial structure.
69. Commercial Building, c.1900, 1139 Market St. Brick Neo-Classical structure.
70. Elsie Bayha Building, c.1915(?), 1941, 1163 Market St. Modernized brick structure.
71. McLain Building, c.1931, S.W. Corner 12th and Market Sts. Masonry modern commercial/office structure.
72. Wm. Paxton Building, 1852-64, 1207-07 Market St. Four-story brick Victorian-Classical Revival structure.
73. Robert Crangle Building, c.1867, 1223 Market St. Three-story brick Italianate commercial structure.
74. Bernhardt Building, 1942(?), 1961, 1225 Market St. Modern brick department store.

FOR HCRS USE ONLY

RECEIVED

DATE ENTERED

**NATIONAL REGISTER OF HISTORIC PLACES
INVENTORY -- NOMINATION FORM**

Wheeling Historic District, Wheeling, Ohio County, West Virginia

CONTINUATION SHEET	Description	ITEM NUMBER	PAGE
		7	9
75.	<u>Central Union Building</u> , c.1900, S.W. corner 14th and Market Sts. Neo-Classical brick office structure.		
76.	<u>Masonic Temple Association Building</u> , 1893, 1409 Market St. Brick Victorian/Neo-Classical structure, served as public library.		
77.	<u>Bruce-Kain Building</u> , c.1870, 1419 Market St. Three-story brick Italianate commercial structure.		
78.	<u>Charles Hanke Building</u> , c.1870, 1421 Market St. Three-story brick Italianate structure.		
79.	<u>Vames Building</u> , c.1895, 1425 Market St. Brick Victorian/Neo-Classical and Medieval overtones, structure.		
80.	<u>Commercial Building</u> , c.1900, 1431 Market St. Brick three-story Victorian/Neo-Classical structure.		
81.	<u>Germania Hall Association Building</u> , c.1897, 1437 Market St. Four-story brick Neo-Classical structure.		
82.	<u>Vaas-Gaus Building</u> , c.1865, 1527 Market St. Three-story brick Italianate structure.		
83.	<u>Thomas Little Building</u> , c.1896, 1520 Market St. Three-story brick Neo-Classical structure. Little was a plumber and manufacturer of ventilating fans and gas burners.		
84.	<u>Thomas Little Building</u> , c.1896, 1548 Market St. Three-story brick Victorian/Neo-Classical structure.		
85.	<u>Richards - Naylor Building</u> , c.1916, 1503-12 Market St. Neo-Classical commercial structure.		
86.	<u>Labor Temple Association Building</u> , c.1920, 1502 Market St. Modern brick commercial structure.		
87.	<u>Rex Theatre</u> , c.1915, 1422 Market St. Modern brick theatre structure.		
88.	<u>Browne Brothers Building</u> , c.1905, 1416 Market St. Brick, Neo-Classical commercial structure.		
89.	<u>Peoples Federal Savings & Loan Association Building</u> , 1939, 1414 Market St. Brick modern commercial structure.		

FOR HCRS USE ONLY
RECEIVED
DATE ENTERED

**NATIONAL REGISTER OF HISTORIC PLACES
INVENTORY -- NOMINATION FORM**

Wheeling Historic District, Wheeling, Ohio County, West Virginia

CONTINUATION SHEET Description ITEM NUMBER 7 PAGE 10

90. Rogers Hotel, c.1920, 44 14th St. Brick Neo-Classical structure.
91. Boreman Building, c.1910, 46-48 14th St. Brick Neo-Classical modern commercial structure.
92. Sonneborn Building, c.1914, 1320 Market St. Brick Neo-Classical commercial building.
93. Hibberd Building, c.1910, 1314 Market St. Brick Neo-Classical jewelry store.
94. Department Store, c.1916, 1310 Market St. Stone & Thomas Developers, modern three-story brick structure in semi-compatible design.
95. Residence, c.1890, 1306 Market St. Rev. John Kain, Developer, brick Victorian structure.
96. Victoria Theatre, c.1910, 1224-28 Market St. Brick Neo-Classical theatre building.
97. McLure Hotel, c.1910, 1200 Market St. Brick Neo-Classical hotel addition.
98. McLure Hotel, 1852, 1200 Market St. Brick Neo-Classical hotel (Wm. Limerick, Architect).
99. McLure Hotel, c.1910, 60-62 12th St. Brick Neo-Classical hotel addition.
100. German Bank of Wheeling, c.1900, N.E. Corner 12th and Market Sts. Brick Neo-Classical commercial structure.
101. Schmulbach Building, c.1900, 1134 Market St. Brick Neo-Classical commercial structure.
102. McFadden Building, c.1906, 1122 Market St. Brick/stone Neo-Classical commercial structure.
103. J. S. Wheat - Joachim Beuter Building, c.1873, 1118 Market St. Three-story brick Victorian structure.
104. Stewart Building, c.1871, 1104 Market St. Brick modernized former residence.
105. Jeremiah Harry Building, c.1869, 1102 Market St. Brick Italianate shop/residence structure (butter and egg depot).

FOR HCRS USE ONLY

RECEIVED

DATE ENTERED

**NATIONAL REGISTER OF HISTORIC PLACES
INVENTORY -- NOMINATION FORM**

Wheeling Historic District, Wheeling, Ohio County, West Virginia

CONTINUATION SHEET Description ITEM NUMBER 7 PAGE 11

- 105A. Commercial Building, c.1890, S.E. Corner 11th and Market Sts. Built by Frederick Unruh - Emma Hoffman, two-story brick Victorian structure.
106. P. J. Greene Building, c.1901, 1500 Main St. Brick Neo-Classical commercial structure.
107. News Publishing Company Building, c.1901, 1500 Main St. Brick Neo-Classical commercial structure.
108. Tempest Hutchinson Building, c.1889, 1222 Main St. Brick Victorian commercial structure. (Saddles and carriage makers)
109. Chapman-Burst Building, c.1895, 1218 Main St. Brick Neo-Classical commercial structure. (Painters and building supply).
110. Elizabeth Greer Building, c.1900, 1214 Main St. Brick modern commercial four-story structure.
111. Alexander Laing Building, 1889, 1212 Main St. Four-story brick Victorian commercial structure (wholesale hardware).
112. Johnson Building, c.1898, 1210 Main St. Brick Victorian/Neo-Classical commercial structure (tin and sheet metal manufacturer).
113. Moore-Johnston Buildings, c.1855, S.E. Corner Main and 12th Sts. Three-story brick Italianate commercial structure.
114. Bank Building, c.1953, 30 12th St. Modern commercial structure blending acceptably.
115. Bank of Ohio Valley, 1906, 32 12th St. Neo-Classical bank building.
116. McLain Building, c.1910, 12th St. Brick Neo-Classical commercial office structure.
117. National Exchange Bank, c.1898, N.E. Corner 12th and Main Sts. Brick and stone Neo-Classical commercial structure.
118. Commercial Building, c.1910, 1132 Main St., Wheeling Hospital and Orphanage Asylum, owners, Neo-Classical multi-story structure.
119. Armstrong-Mendel Building, c.1865, 1122 Main St. Brick Italianate commercial structure.

UNITED STATES DEPARTMENT OF THE INTERIOR
HERITAGE CONSERVATION AND RECREATION SERVICE

FOR HCRS USE ONLY
RECEIVED
DATE ENTERED

NATIONAL REGISTER OF HISTORIC PLACES INVENTORY -- NOMINATION FORM

Wheeling Historic District, Wheeling, Ohio County, West Virginia

CONTINUATION SHEET Description ITEM NUMBER 7 PAGE 12

- 120. C. J. Welty Building, c.1860, 1120 Main St. Three-story brick Italianate structure.
- 121. Commercial Structure, c.1860, 1118 Main St. Four-story brick Italianate structure.
- 122. Norton Building, c.1905, Main St. Brick Neo-Classical three-story structure.
- 123. Kennedy Building, c.1860, 1058 Main St. Brick Italianate structure (dry goods store)
- 124. Wm. H. Colvig Building, c.1900, 1056 Main St. Brick Neo-Classical millinery store.
- 125. Commercial Structure, c.1855, 1052 Main St. Three-story brick Italianate structure.
- 126. Jones Building, c.1877, 1050-48 Main St. Three-story brick Victorian/Classical structure.
- 127. Frederick Myers Building, c.1908, 1046 Main St. Three-story brick Victorian structure.
- 128. Pollock-Walters Building, c.1870, 1044 Main St. Three-story brick Victorian-Italianate structure.
- 129. Zinn, Steger, Graham Building, c.1868, 1040 Main St. Brick Classical Revival commercial buildings (dyers and scourers).
- 130. Stone Department Store, 1914, 1130 Main St. Neo-Classical/Romanesque Revival commercial structure (Franzheim, Giesey, Faris, Architects).
- 131. Dusch Building, c.1860, Main St. Three-story brick Italianate structure incorporated into Stone Department Store building.
- 132. Heil Quiwn Building, c.1925(?), 1933, 1012 Main St. Three-story brick Neo-Classical commercial drug company structure.
- 133. Wm. Paxton - Peter Zinn Buildings, c.1855, 1001 Main St. Three-story brick Italianate confectionary
- 134. Wm. Paxton - Peter Zinn Buildings, c.1855, 10-32 10th St. Three-story brick Italianate commercial structure.

UNITED STATES DEPARTMENT OF THE INTERIOR
HERITAGE CONSERVATION AND RECREATION SERVICE

FOR HCRS USE ONLY

RECEIVED

DATE ENTERED

NATIONAL REGISTER OF HISTORIC PLACES INVENTORY -- NOMINATION FORM

Wheeling Historic District, Wheeling, Ohio County, West Virginia

CONTINUATION SHEET Description ITEM NUMBER 7 PAGE 13

135. Loft Manufacturing Co. - Hawley Building, 1912-14, 1025 Main St. Brick Neo-Classical office structure.
136. Patrick Kennedy Buildings, c.1870, 1033-39 Main St. Three-story brick Italianate dry goods and foundry wareroom.
137. Harrison Dunlevy Building, c.1879(?), 1041-43 Main St. Three-story modernized brick commercial structure.
138. Campbell-Heymon Building, c.1864, 1047 Main St. Two-story brick Classical tin shop.
139. Knote Building, c.1886, 1049 Main St. Brick Victorian/Neo-Classical commercial structure.
140. Knox Building, c.1850, 1053 Main St. Three-story brick Classical Revival structure.
141. Knox Building, c.1850, 1057 Main St. Three-story brick Classical Revival commercial/residence structure.
142. Stealey Building, c.1918, 1059 Main St. Modern brick structure.
143. Flaccus Building, c.1898, 1063 Main St. Three-story brick commercial structure.
144. Hawley-Heymon Building, 1876, 1067 Main St. Three-story brick Neo-Classical structure.
145. Heinberg Building, c.1888, 1069 Main St. Two-story brick Victorian structure.
146. Sheppard Building, c.1862(?), 1073 Main St. Modern commercial structure.
147. Gallaher Buildings, c.1894(?), 1960, 1101 Main St. Modernized brick commercial structures.
148. McCulley Building, c.1920, 1107 Main St. Modern Neo-Classical three-story brick structure.
149. Front Buildings, c.1880(?), 1111 Main St. Three-story Victorian structure.
150. Zane Building, c.1900, 1113 Main St. Four-story brick commercial structure.

FOR HCRS USE ONLY

RECEIVED

DATE ENTERED

**NATIONAL REGISTER OF HISTORIC PLACES
INVENTORY -- NOMINATION FORM**

Wheeling Historic District, Wheeling, Ohio County, West Virginia

CONTINUATION SHEET Description ITEM NUMBER 7 PAGE 14

151. Fidelity & Columbia Trust Co. Building - Reichart Co. Department Store, 1914, 1923, 1121 Main St. Modernized facade of department store structure.
152. Unruh Building, c.1890, 1125-27 Main St. Three-story brick Victorian commercial structure.
153. Hankmeier Building, c.1860, 1133 Main St. Two-story brick Victorian/Classical structure.
154. Reilly Building, c.1877, 1972, 1139 Main St. Brick modern structure.
155. Augustus Pollack Building, c.1863, 1217 Main St. Three-story brick Italianate notions store.
156. Goodwin Building, c.1897, 1227 Main St. Four-story brick Neo-Classical commercial structure.
157. List-Sauvage^{ot} Building, c.1852, 1223 Main St. Three-story brick Classical Revival structure. (Barber and hair dressing salon)
158. Gardell-Rogers Building, c.1877(?), 1962, 1301 Main St. Brick, modernized facade commercial structure.
159. Hildreth Building, c.1870, 1313 Main St. Three-story brick Italianate structure.
160. Hildreth Building, c.1870, 1315 Main St. Three-story brick Italianate structure.
161. Hubbard Building, c.1850, 1319 Main St. Three-story Classical Revival structure.
162. Hubbard Building, c.1850, 14th St. Three-story brick Classical Revival structure.
163. Hubbard Building, c.1850, 13 14th St. Two-story brick Classical Revival structure.
164. Hubbard Building, c.1898, 14th St. Two-story brick Victorian structure. (Wheeling Steel & Iron Co. office)
165. Alexander Durst Building, c.1904, 14th St. Modern brick commercial structure.
166. List-Bodley Building, c.1870, Water St. Three-story brick Classical Revival structure.

UNITED STATES DEPARTMENT OF THE INTERIOR
HERITAGE CONSERVATION AND RECREATION SERVICE

FOR HCRS USE ONLY

RECEIVED

DATE ENTERED

**NATIONAL REGISTER OF HISTORIC PLACES
INVENTORY -- NOMINATION FORM**

Wheeling Historic District, Wheeling, Ohio County, West Virginia

CONTINUATION SHEET Description ITEM NUMBER 7 PAGE 15

167. Joseph Bodley Building, c.1870, Water St. Four-story Classical Revival structure.
168. Peterson-Boyd Building, c.1900, 1230 Water St. Modern brick commercial structure.
169. Hughes-Leech Building, c.1850, N.E. Corner 12th & Water Sts. Three-story brick Classical Revival structure. (Merchant tailor-mens furnishing goods)
170. Adams-Seamon Building, c.1866-71, Water St. between 12th and 11th Sts. Brick Italianate structure.
171. Commercial Structure, c.1870, 1147 Water St. Brick Italianate structure.
172. Windsor Hotel, 1914, Water St. between 12th & 11th Sts. Brick Neo-Classical high-rise hotel. (Charles W. Bates, Architect)
173. Fidelity & Columbia Trust Co. Building - Reichart Co. Department Store, 1914,1923, Water St. between 11th & 12th Sts. Brick Neo-Classical structure.
174. McCulley Building, c.1920, Water St. between 11th & 12th Sts. Brick modern commercial structure.
175. Ritz Building, c.1926, S.E. Corner Water & 11th Sts. Brick modern commercial structure.
176. Paull Building, c.1920, Eoff St. at 13th St. Single-story brick modernized structure.

NON-CONFORMING INTRUSIONS DETRACTING FROM THE INTEGRITY OF THE DISTRICT:

1. Cater Building, c.1959, 1613 Market St. Two-story modern brick commercial structure.
2. Glen Straub Auto Sales Building, c.1968, 6-10 16th St. One-story metal frame commercial structure.
3. Glen Straub Service Shop, c.1970, South St. One-story metal frame commercial structure.
4. Columbia Gas of West Virginia, 1961, 44 16th St. Modern office tower.

FOR HCRS USE ONLY

RECEIVED

DATE ENTERED

**NATIONAL REGISTER OF HISTORIC PLACES
INVENTORY -- NOMINATION FORM**

Wheeling Historic District, Wheeling, Ohio County, West Virginia

CONTINUATION SHEET Description ITEM NUMBER 7 PAGE 16

5. Kennedy Building, c.1959, 1535 Market St. Brick two-story modern commercial structure.
6. Gas Station, c.1951, N.W. Corner 16th & Chapline Sts. Single-story modern structure.
7. Chesapeake & Potomac Telephone Building, c.1962, 1515 Chapline St. Two-story modern brick structure.
8. Bell Telephone Co. Addition, c.1962, 1501 Chapline St. Modern brick structure.
9. Garage, Eoff St. between 14th & 15th Sts. Single-story modern brick structure.
10. McCamic & McCamic Law Office, 1968, 56 14th St. Contemporary brick one-story structure.
11. Office Building, c.1950, 1301 Eoff St. Single-story modern brick structure.
12. Presbyterian Church House, 1957, 1307 Chapline St. Two-story modern brick structure.
13. Commercial Building, 1949, 1970, 1217 Chapline St. Built by Robert Phillips, single-story brick modern structure.
14. International Order of Odd Fellows Lodge, 1951. Two-story modern brick structure. S.W. corner 12th & Chapline St.
15. Garage/Storage Building. Alley between Chapline & Market Sts. between 11th and 12th Sts. Single-story concrete block structure.
16. Security National Bank & Trust Co. 11th St. between Market and Chapline Sts. Drive-thru teller windows.
17. Security National Bank & Trust Building, c.1959, 1114 Market St. Brick and marble modern structure.
18. Commercial Building, c.1944(?), 1130 Market St. Modern brick structure.
19. Security Trust Co. Building, c.1920, N.E. Corner 11th & Market Sts. Two-story modern brick structure.
20. Commercial Building, 1958, 1056 Market St. Single-story modern brick structure.

UNITED STATES DEPARTMENT OF THE INTERIOR
HERITAGE CONSERVATION AND RECREATION SERVICE

FOR HCRS USE ONLY
RECEIVED
DATE ENTERED

**NATIONAL REGISTER OF HISTORIC PLACES
INVENTORY -- NOMINATION FORM**

Wheeling Historic District, Wheeling, Ohio County, West Virginia

CONTINUATION SHEET Description ITEM NUMBER 7 PAGE 17

21. Garage/Storage. Alley between Chapline and Market Sts. and between 11th and 10th Sts. Concrete block modern structure.
22. Commercial Building, c.1915, 1011-07 Market St. Two-story modern brick structure.
23. Restaurant. Main St. between 10th and 11th Sts. Single-story wood frame modern structure.
24. Half Dollar Bank Building, 1974, Market Plaza, Single-story modern brick structure.
25. Horne's Department Store, 1969, 11th St. at Market St. Modern brick-concrete block building.
26. Hampton Zane Buildings, c.1860, S.E. Corner 11th & Main Sts. Three-story brick modernized commercial structure.
27. G. C. Murphy Department Store, c.1952, Main St. between 11th & 12th Sts. Rear of store, modern brick structure.
28. L. S. Good Department Store, c.1911,1970, 1141 Main St. Modern brick commercial structure.
29. Charles Bachman Building, c.1913(?), 1125 Market St. Modern commercial structure.
30. Commercial Building,1960, 1127 Market St. Modern commercial structure.
31. Wheeling National Bank Building, c.1968, 1145 Market St. Modern brick commercial structure.
32. Restaurant Building,1978, 12th St. between Market and Main Sts. Concrete block modern structure.
33. Edward Hazlett Building, c.1920,1958, 35 12th St. Modern brick commercial structure.
34. Wm. Hare Building, c.1870(?), 31 12th St. Modernized brick commercial structure.
35. Commercial Buildings, c.1870, 1900(?), 27-29 12th St. Modernized brick structure.
36. Chase Building, c.1964, 1215 Market St. Modern commercial structure.

FOR HCRS USE ONLY

RECEIVED

DATE ENTERED

**NATIONAL REGISTER OF HISTORIC PLACES
INVENTORY -- NOMINATION FORM**

Wheeling Historic District, Wheeling, Ohio County, West Virginia

CONTINUATION SHEET Description ITEM NUMBER 7 PAGE 18

37. Henrietta Baum Building, 1928, 1219 Market St. Modern brick commercial structure.
38. Bernhardt Building, 1961, 1225 Market St. Modern brick department store.
39. Wheeling Dollar Bank Building, 1976, Bank plaza, modern glass commercial structure.
40. Phillips Building, c.1946, 1411-13 Market St. Modern brick commercial structure.
41. Garage/Storage. Alley between 14th & 16th Sts. and between Market and Main Sts. Concrete block structure.
42. Half Dollar Bank Building, c.1960, 1501 Market St. Modern brick/glass structure.
43. News Publishing Co. Building, c.1956, Main St. between 14th & 16th Sts. Modern brick mechanical structure.
44. Schiffler Building, c.1950, N.W. Corner Main and 14th Sts. Modern brick gas station.
45. Charles Sledd Building, 1971, N.E. corner Water and 14th Sts. Modern brick/concrete block commercial structure.
46. Boury Building, 1977, 1303 Main St. Modern single-story concrete block commercial structure.
47. Berry Inc. Building, c.1953, Water St. between 12th and 14th Sts.
48. Bank of Wheeling Building, 1975, Water St. between 14th and 12th Sts. Modern brick/glass drive-thru window.
49. Wheeling National Bank Building, 1976, Water St. between 14th and 12th Sts. Modern brick/glass drive-thru window.
50. Sigesmund Building, 1965, 1145 Main St. Modern brick bank structure.
51. Skilken Building, 1972, 1143 Main St. Modern brick office structure.
52. Maury Building, c.1965, 1061 Main St. Modern brick doctor's office/apartment structure.
53. Commercial Building, c.1960(?) 1156 Market St. Modern brick structure.

UNITED STATES DEPARTMENT OF THE INTERIOR
HERITAGE CONSERVATION AND RECREATION SERVICE

FOR HCRS USE ONLY

RECEIVED

DATE ENTERED

NATIONAL REGISTER OF HISTORIC PLACES INVENTORY -- NOMINATION FORM

Wheeling Historic District, Wheeling, Ohio County, West Virginia

CONTINUATION SHEET Description ITEM NUMBER 7 PAGE 19

BUILDINGS OF NATIONAL, MAJOR, AND PIVOTAL SIGNIFICANCE

22. W. M. Marsh - Wheeling Drug Co. Building, c.1915, S. W. Corner Main and 12th Sts. The Marsh-Wheeling Drug Co. Building, designed by noted Wheeling architect, Charles W. Bates, was originally the bank and office building for the National Bank of West Virginia. The reinforced concrete, fireproof building features an exterior of white, gold, and olive green terra cotta.

8. Significance

Period	Areas of Significance—Check and justify below			
<input type="checkbox"/> prehistoric	<input type="checkbox"/> archeology-prehistoric	<input type="checkbox"/> community planning	<input type="checkbox"/> landscape architecture	<input type="checkbox"/> religion
<input type="checkbox"/> 1400-1499	<input type="checkbox"/> archeology-historic	<input type="checkbox"/> conservation	<input type="checkbox"/> law	<input type="checkbox"/> science
<input type="checkbox"/> 1500-1599	<input type="checkbox"/> agriculture	<input type="checkbox"/> economics	<input type="checkbox"/> literature	<input type="checkbox"/> sculpture
<input type="checkbox"/> 1600-1699	<input checked="" type="checkbox"/> architecture	<input type="checkbox"/> education	<input type="checkbox"/> military	<input type="checkbox"/> social/ humanitarian
<input type="checkbox"/> 1700-1799	<input type="checkbox"/> art	<input type="checkbox"/> engineering	<input type="checkbox"/> music	<input checked="" type="checkbox"/> theater
<input checked="" type="checkbox"/> 1800-1899	<input checked="" type="checkbox"/> commerce	<input checked="" type="checkbox"/> exploration/settlement	<input type="checkbox"/> philosophy	<input checked="" type="checkbox"/> transportation
<input checked="" type="checkbox"/> 1900-	<input type="checkbox"/> communications	<input type="checkbox"/> industry	<input checked="" type="checkbox"/> politics/government	<input type="checkbox"/> other (specify)
		<input type="checkbox"/> invention		

Specific dates

Builder/Architect

Statement of Significance (in one paragraph)

The Wheeling Historic District is an excellent example of 19th and early 20th century architecture reflecting commercial development that provided the impetus to produce a unique regional vernacular style. The District is naturally bounded by Wheeling Hill, Wheeling Creek, and the Ohio River at the east and west, and by the Wheeling Suspension Bridge together with the Interstate Highway System at the north, and the Baltimore and Ohio Railroad tracks to the south. The District forms the Central Business District of modern Wheeling, and despite several intrusions in the historic area, it still retains a late 19th century ambience. This historic Central Business District contains the city's concentration of large commercial structures and is surrounded today, as it was originally, by dense residential development that is architecturally significant in its own right.

It was at the confluence of Wheeling Creek and the Ohio River that Ebenezer Zane, together with his brothers Jonathan, Silas, and Andrew, staked their claim to what would become the City of Wheeling. The Ohio River was a natural artery of transportation for both Indian and White, and this together with the fact that lands west of the river were Indian, ultimately led to frequent confrontations between the settlers and the Indians. As a result, the construction of a military outpost called Fort Fincastle was begun in 1774 for protection. With the advent of the Revolution in 1776, the fort was renamed Fort Henry after Virginia's Governor Patrick Henry, and the following year fell subject to a combined British-Indian attack which left Wheeling burned to the ground except for the fort itself. The settlers managed to survive the future raids up through 1782 which is said to be the last skirmish of the Revolutionary War. With peace assured, the region was allowed to grow, and the first city plots were laid out in 1793. With the erection of Shepherd Hall in 1798 and the many fine McColloch homes after the turn of the century, the strong economic base of the region seemed assured.

It was not until after the economic slump during the War of 1812 that Wheeling really became the commercial business center it would enjoy for over a century. When Captain Shreve constructed the first steamboat in Wheeling in 1815, it opened up a new era of expansion. The "George Washington" was the beginning of trade operations down river to New Orleans. By 1818 the National Pike was completed from Wheeling to Cumberland, Maryland, and by 1825 the Chesapeake and Ohio Canal linked Cumberland to Georgetown, Maryland, on the Potomac River. This opened the main method of trade communications between East and West and thus opened the Northwest Territory to expansion. Ultimately by 1831, Wheeling was designated an inland port of entry and became the most significant city in the upper Ohio Valley. In 1849, the world's longest suspension bridge was erected across the Ohio River to Wheeling Island enabling affluent society to erect homes in the "Garden District" and ultimately providing the National Pike a method for westward expansion to the Ohio Territory. With the completion of the Baltimore and Ohio Railroad to Wheeling in 1853, population growth skyrocketed as did commerce and industry which both contributed to the architectural development of the Central Business District.

UNITED STATES DEPARTMENT OF THE INTERIOR
HERITAGE CONSERVATION AND RECREATION SERVICE

FOR HCRS USE ONLY

RECEIVED

DATE ENTERED

NATIONAL REGISTER OF HISTORIC PLACES INVENTORY -- NOMINATION FORM

Wheeling Historic District, Wheeling, Ohio County, West Virginia

CONTINUATION SHEET Significance ITEM NUMBER 8 PAGE 2

The Civil War saw Wheeling thrust into national significance in that in 1861 at the United States Custom House, the citizens of Wheeling declared the Acts of Secession by the Virginia Legislature in Richmond null and void, and thus established the restored government of the Dominion of Virginia housed in the Linsly Institute Building as the legitimate capitol. By 1863 President Lincoln's signature created a separate state, West Virginia, with Generals Rosecrans and Fremont stationed at the new capital of Wheeling.

It was during this period of the second half of the 19th century that industrial growth reached its pinnacle. Coal and iron were at the forefront of expansion with many buildings boasting Classical cast iron detail in the historic Central Business District attesting to the craftsmanship of the region. The Sweeney family of Wheeling, too, produced beautiful craftsmanship in superb glass and crystal, much of which may be seen today around the city. Even though Wheeling ultimately lost its capitol to Charleston, trade and commerce blossomed with merchant families like the Hess's, the Stifels producing textiles, and the Bloch's manufacturing of tobacco products. Major breweries sprang up, too, contributing to the wealth of the area with the Reymanns and Schmulbachs leading the way. Wheeling eventually became known as "Nail City" as the largest manufacturer of cut nails in the world, and by the turn of the century, the undisputed head of the upper Ohio Valley. With the coming of the street car, many families were enabled to move out on National Road and commute to the markets and commercial establishments of the District thus expanding the city to new areas. However, even though by 1925 Wheeling was the largest manufacturer of proprietary drugs, its prominence slipped away and Pittsburgh took over as leader of the region.

It was during this economic heyday of Wheeling that most of the buildings within the Central Business District were constructed. It was progressive architectural firms such as Franzheim, Giesey, and Faris that reflected their awareness of regional architecture of Henry Hobson Richardson in Pittsburgh and Louis Sullivan in Chicago in their works such as the City Bank Building and the Bank of Wheeling Building, yet local materials and craftsmen combined to form a unique style that reflects the vernacular of Wheeling. Applique of style in glass, iron, and stone form the 19th century ambience still so prevalent today.

Despite insensitive modern intrusions within the District, Wheeling still retains its character, yet a serious borderline case exists if demolition is allowed to run unchecked. Attempts at renovation have helped upgrade existing conditions, yet they remain largely token at best. However, building conditions within the District are sound and will provide excellent opportunity for future renovation.

FOR HCRS USE ONLY

RECEIVED

DATE ENTERED

**NATIONAL REGISTER OF HISTORIC PLACES
INVENTORY -- NOMINATION FORM**

Wheeling Historic District, Wheeling, West Virginia

CONTINUATION SHEET

ITEM NUMBER 8

PAGE 3

Summation of Significance

The Wheeling Historic District contains West Virginia's most significant concentration of nineteenth century commercial architecture. The large number of brick and stone-trimmed buildings identify nationally popular architectural modes represented in the Classical and Neo-Classical Revival, the Romanesque, and in the Victorian genre and eclecticism of which the Italianate is predominate. Wheeling's prominence as a center of and gateway to the nineteenth century West is reflected in the number of prominent architects who were commissioned to aggrandize the city. In 1837 Thomas Ustick Walter designed the Greek Revival Merchants and Mechanics Bank (Exchange Bank) that stood at the corner of Main Street and Monroe Street (12th Street) until c. 1900. Ammi B. Young produced the U.S. Custom House (Wheeling Independence Hall) in 1859. The rapid nineteenth century expansion of Wheeling and its resulting building boom fostered the emergence of West Virginia's earliest professional architectural community whose leaders, by the turn-of-the-century, were Edward Bates Franzheim, Fred Faris, Millard F. Giesey, and Charles Bates.

Significant in the Growth of Wheeling was the completion of the Cumberland or National, Road to Wheeling in 1818. The development of the upper Ohio Valley and of large sections of the U.S. Interior was made possible by this highway over which passed thousands of passengers and tons of freight in Conestoga wagons and stagecoaches. The Wheeling Suspension Bridge, designed and built by Charles Ellet, Jr. in 1849, carried traffic of the National Road over the Ohio River from Wheeling to Wheeling Island. This bridge, whose approach forms part of the northern boundary of the Wheeling Historic District, is the most significant extant Antebellum engineering structure in the United States and, according to Professor Emory Kemp of West Virginia University, probably the oldest important bridge in the New World.

Events significant in the history of West Virginia and the United States occurred at Wheeling in the years 1861-63. Following the secession of Virginia from the Union, a series of conventions, beginning in 1861, were held at Wheeling denouncing Virginia's action and creating a "restored Government of Virginia" friendly to the United States and in sympathy with anti-secessionist feeling in the Virginia counties west of the Alleghenies.

The second session of the Second Wheeling Convention that met in August 1861, dealt with the question of statehood for West Virginia. The formation of the state, however, occurred following the First Constitutional Convention (November 26, 1861-February 18, 1862, and February 12-20, 1863). With the approval of

UNITED STATES DEPARTMENT OF THE INTERIOR
HERITAGE CONSERVATION AND RECREATION SERVICE

FOR HCRS USE ONLY

RECEIVED

DATE ENTERED

NATIONAL REGISTER OF HISTORIC PLACES INVENTORY -- NOMINATION FORM

Wheeling Historic District, Wheeling, West Virginia

CONTINUATION SHEET

ITEM NUMBER 8 PAGE 4

the Constitution by the people on April 3, 1862, the Restored Government, seated in the Wheeling Custom House, gave official approval of Virginia for the creation of the new state. Following Congressional action in July and December, 1862, President Lincoln signed the statehood bill. After West Virginia's approval of an important amendment to the new Constitution, President Lincoln issued a proclamation stating that sixty days following April 20, 1863, West Virginia would become a state. On June 20, 1863, West Virginia became the 35th state.

Events leading to West Virginia's creation were centered in what is today the Wheeling Historic District. The Custom House (#1 of the descriptive statement), also called Independence Hall, was actually the administration center of the government (June 20, 1861, to June 20, 1863) of Virginia loyal to the Union. It was also the site West Virginia's First Constitutional Convention.

Linsly Institute (#2 of descriptive statement) was the first capitol of West Virginia (June 20, 1863 to April 1, 1870, and from May 23, 1875, to December 4, 1876) and the site of the inauguration of West Virginia's first governor, Arthur I. Boreman.

Wheeling was the capital of West Virginia from 1863 to 1870 and from 1875 to 1885. The second capitol at Wheeling (destroyed) was located on the site of the present (1979) city-county building.

The formation of West Virginia in events at Wheeling in 1863 insured protection of important Union transportation and communication links, including the Ohio River, the B&O Railroad, and the National Road.

Summary by Rosney Collins

9. Major Bibliographical References

Atlas of the City of Wheeling, West Virginia. L. J. Richards & Co.,
Philadelphia 1889.

10. Geographical Data

Acreeage of nominated property 55.8 Approx.

Quadrangle name Wheeling, W. Va. - Ohio

Quadrangle scale 1:24000

UMT References

A	<u>1</u> <u>7</u>	<u>5</u> <u>2</u> <u>3</u> <u>6</u> <u>2</u> <u>0</u>	<u>4</u> <u>4</u> <u>3</u> <u>5</u> <u>4</u> <u>2</u> <u>0</u>	B	<u>1</u> <u>7</u>	<u>5</u> <u>2</u> <u>3</u> <u>6</u> <u>3</u> <u>0</u>	<u>4</u> <u>4</u> <u>3</u> <u>5</u> <u>3</u> <u>2</u> <u>0</u>
	Zone	Easting	Northing		Zone	Easting	Northing
C	<u>1</u> <u>7</u>	<u>5</u> <u>2</u> <u>3</u> <u>6</u> <u>8</u> <u>0</u>	<u>4</u> <u>4</u> <u>3</u> <u>5</u> <u>3</u> <u>2</u> <u>0</u>	D	<u>1</u> <u>7</u>	<u>5</u> <u>2</u> <u>3</u> <u>7</u> <u>0</u> <u>0</u>	<u>4</u> <u>4</u> <u>3</u> <u>5</u> <u>2</u> <u>2</u> <u>0</u>
E	<u>1</u> <u>7</u>	<u>5</u> <u>2</u> <u>3</u> <u>7</u> <u>6</u> <u>0</u>	<u>4</u> <u>4</u> <u>3</u> <u>5</u> <u>2</u> <u>2</u> <u>0</u>	F	<u>1</u> <u>7</u>	<u>5</u> <u>2</u> <u>3</u> <u>7</u> <u>8</u> <u>0</u>	<u>4</u> <u>4</u> <u>3</u> <u>5</u> <u>0</u> <u>7</u> <u>0</u>
G	<u>1</u> <u>7</u>	<u>5</u> <u>2</u> <u>3</u> <u>9</u> <u>0</u> <u>0</u>	<u>4</u> <u>4</u> <u>3</u> <u>5</u> <u>0</u> <u>8</u> <u>0</u>	H	<u>1</u> <u>7</u>	<u>5</u> <u>2</u> <u>3</u> <u>9</u> <u>4</u> <u>0</u>	<u>4</u> <u>4</u> <u>3</u> <u>4</u> <u>6</u> <u>8</u> <u>0</u>

Verbal boundary description and justification

Boundary marks as shown on attached map described as beginning at a point on 10th Street at the Wheeling Suspension Bridge and the Ohio River, then proceed

List all states and counties for properties overlapping state or county boundaries

state	code	county	code
state	code	county	code

11. Form Prepared By

name/title Frederick Ellsworth Kleyle, Intern

organization National Trust for Historic Preservation date 11/1/78

street & number 2618 Short Street telephone 304-348-0240

city or town New Orleans state Louisiana

12. State Historic Preservation Officer Certification

The evaluated significance of this property within the state is:

national state local

As the designated State Historic Preservation Officer for the National Historic Preservation Act of 1966 (Public Law 89-665), I hereby nominate this property for inclusion in the National Register and certify that it has been evaluated according to the criteria and procedures set forth by the Heritage Conservation and Recreation Service.

State Historic Preservation Officer signature

Clarence Moran

Director, Historic Preservation Unit, WV Department

title of Culture and History

date October 17, 1979

For HCRS use only

I hereby certify that this property is included in the National Register

date

Keeper of the National Register

Attest:

date

Chief of Registration

UNITED STATES DEPARTMENT OF THE INTERIOR
HERITAGE CONSERVATION AND RECREATION SERVICE

FOR HCRS USE ONLY

RECEIVED

DATE ENTERED

**NATIONAL REGISTER OF HISTORIC PLACES
INVENTORY -- NOMINATION FORM**

Wheeling Historic District, Wheeling, Ohio County, West Virginia

Major Bibliographical

CONTINUATION SHEET References ITEM NUMBER 9 PAGE 2

City Directories, Oglebay Museum, Wheeling, West Virginia.

Deed Books, Tax Records and Land Books, Ohio County Courthouse, Wheeling,
West Virginia.

Files of the Historic American Buildings Survey, 1100 L Street, N.W.,
Washington, D. C.

Intelligencer Newspaper Records, Ohio County Public Library, Wheeling,
West Virginia.

Wheeling Daily Register, Ohio County Public Library, Wheeling, West Virginia.

Map of the City of Wheeling & Suburbs, Ohio Co., Virginia. Manfred & Simpson,
Cincinnati, 1853.

Map of the City of Wheeling, South Wheeling, and Lagrange, West Virginia.
F. W. Beers & Co. 1871.

UNITED STATES DEPARTMENT OF THE INTERIOR
HERITAGE CONSERVATION AND RECREATION SERVICE

FOR HCRS USE ONLY

RECEIVED

DATE ENTERED

**NATIONAL REGISTER OF HISTORIC PLACES
INVENTORY -- NOMINATION FORM**

Wheeling Historic District, Wheeling, Ohio County, West Virginia

Major Bibliographical

CONTINUATION SHEET References ITEM NUMBER 9 PAGE 2

City Directories, Oglebay Museum, Wheeling, West Virginia.

Deed Books, Tax Records and Land Books, Ohio County Courthouse, Wheeling,
West Virginia.

Files of the Historic American Buildings Survey, 1100 L Street, N.W.,
Washington, D. C.

Intelligencer Newspaper Records, Ohio County Public Library, Wheeling,
West Virginia.

Wheeling Daily Register, Ohio County Public Library, Wheeling, West Virginia.

Map of the City of Wheeling & Suburbs, Ohio Co., Virginia. Manfred & Simpson,
Cincinnati, 1853.

Map of the City of Wheeling, South Wheeling, and Lagrange, West Virginia.
F. W. Beers & Co. 1871.

UNITED STATES DEPARTMENT OF THE INTERIOR
HERITAGE CONSERVATION AND RECREATION SERVICE

FOR HCRS USE ONLY

RECEIVED

DATE ENTERED

**NATIONAL REGISTER OF HISTORIC PLACES
INVENTORY -- NOMINATION FORM**

Wheeling Historic District, Wheeling, Ohio County, West Virginia

CONTINUATION SHEET Geographical Data ITEM NUMBER 10 PAGE 2

east to Market Street. Proceed south along Market Street to Bridge Street alley, then proceed east to rear alley of property facing Market Street. Proceed south along said alley to 11th Street, then proceed east to Chapline Street. Proceed south along Chapline Street to 12th Street, then proceed east along 12th Street to Eoff Street. Proceed south along Eoff Street to 15th Street, then proceed west to Chapline Street. Proceed south to the Baltimore and Ohio Railroad elevated tracks and proceed west along said tracks to Wheeling Creek. Proceed northwest along said creek to its intersection at Main Street. Proceed north along Main Street to 14th Street and proceed west to Water Street. Proceed north along Water Street to 11th Street. Proceed north at rear of property facing Main Street and at the banks of the Ohio River to point of beginning.

FOR HCRS USE ONLY
RECEIVED
DATE ENTERED

NATIONAL REGISTER OF HISTORIC PLACES INVENTORY -- NOMINATION FORM

Wheeling Historic District, Wheeling, Ohio County, West Virginia

CONTINUATION SHEET

ITEM NUMBER 10 PAGE 3

Geographical Data:

<u>ZONE</u>	<u>EASTING</u>	<u>NORTHING</u>
I. 17	523 840	4434 670
J. 17	523 840	4434 600
K. 17	523 690	4434 580
L. 17	523 600	4434 640
M. 17	523 580	4434 840
N. 17	523 480	4434 840
O. 17	523 480	4435 180
17	523 450	4435 400

WHEELING HISTORIC DISTRICT
 WHEELING, OHIO CO., WEST VIRGINIA

UTM'S

- A 17/523 620/4435 420
- B 17/523 630/4435 320
- C 17/523 620/4435 320
- D 17/523 700/4435 220
- E 17/523 760/4435 220
- F 17/523 780/4435 070
- G 17/523 900/4434 080
- H 17/523 940/4434 680
- I 17/523 840/4434 670
- J 17/523 840/4434 600
- K 17/523 690/4434 580
- L 17/523 600/4434 640
- M 17/523 580/4434 840
- N 17/523 480/4434 840
- O 17/523 480/4435 180
- P 17/523 450/4435 400

QUAD
 WHEELING, W. VA., - OHIO
 1:24,000

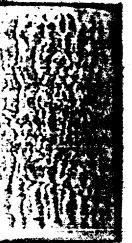
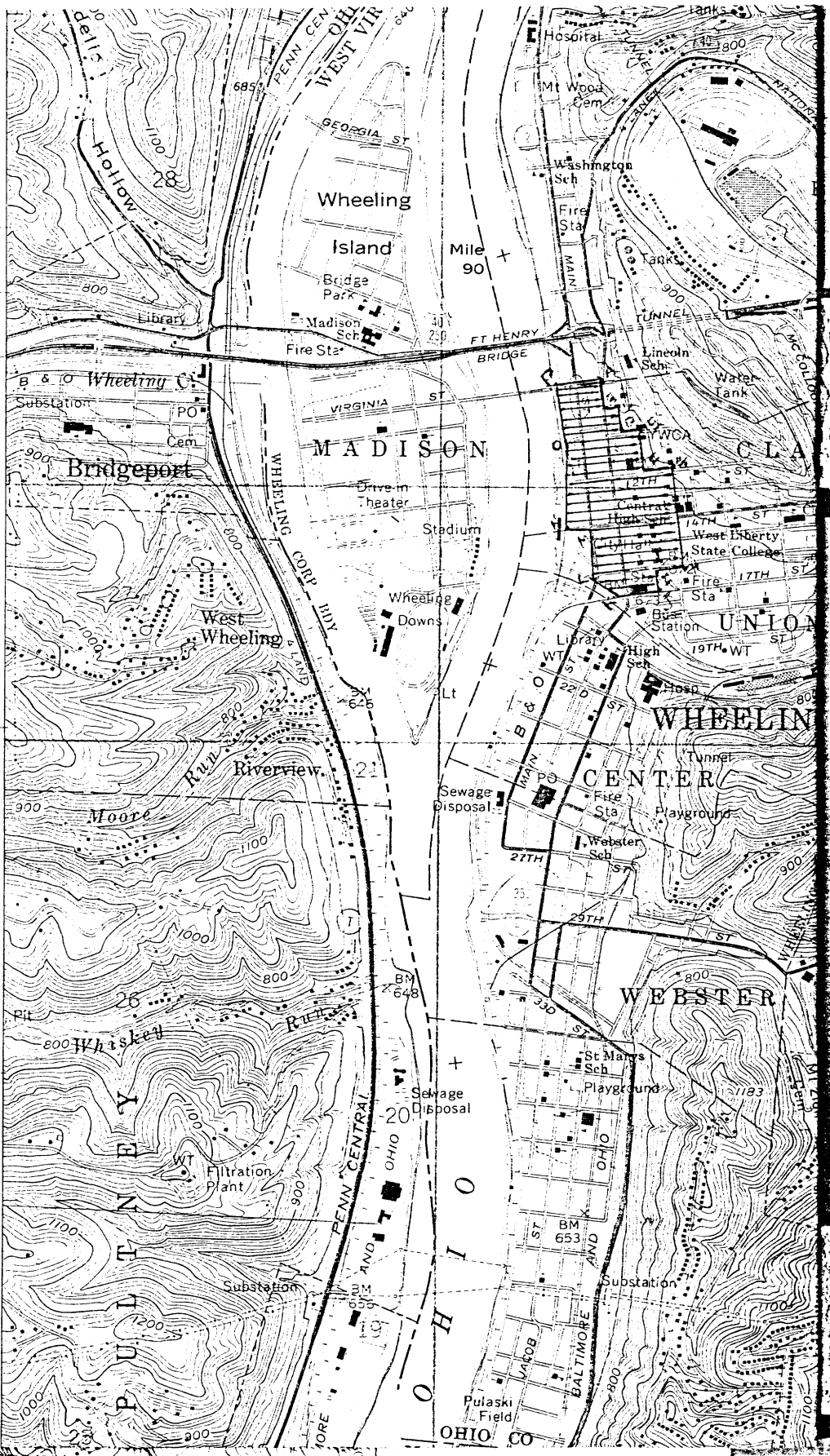

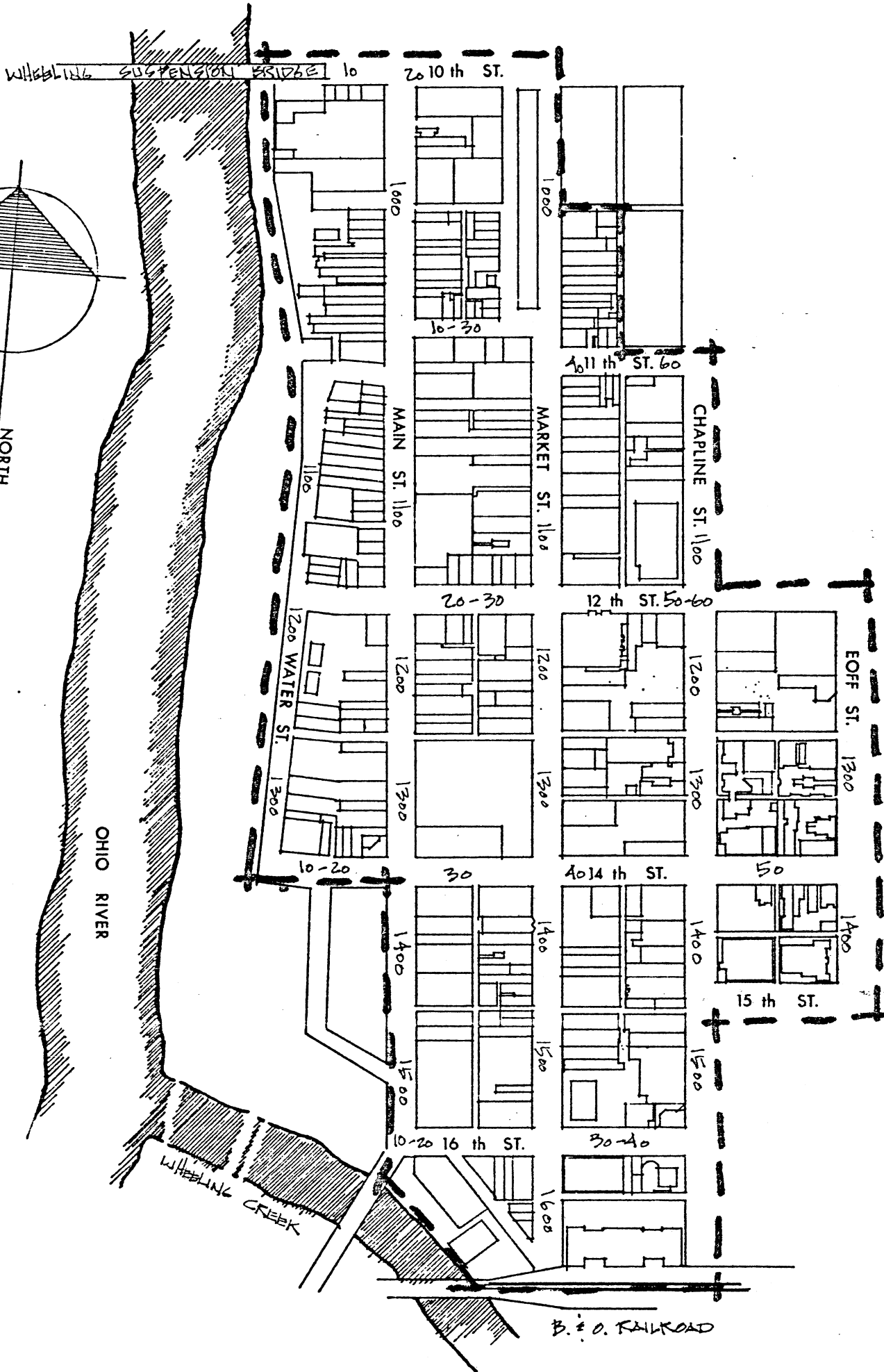
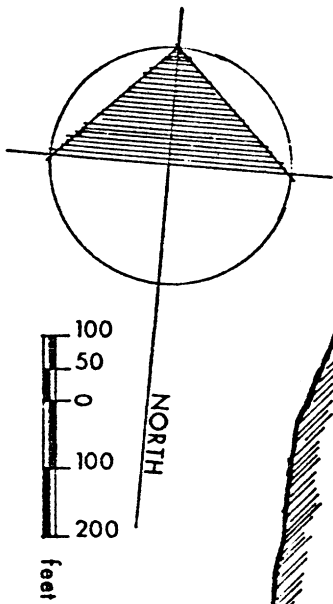

Historic District Boundary
 Wheeling Historic District
 Ohio County
 Wheeling, West Virginia

BUILDINGS OF NATIONAL, MAJOR, OR
RIVAL SIGNIFICANCE
 WHEELING HISTORIC DISTRICT
 OHIO COUNTY
 WHEELING, WEST VIRGINIA

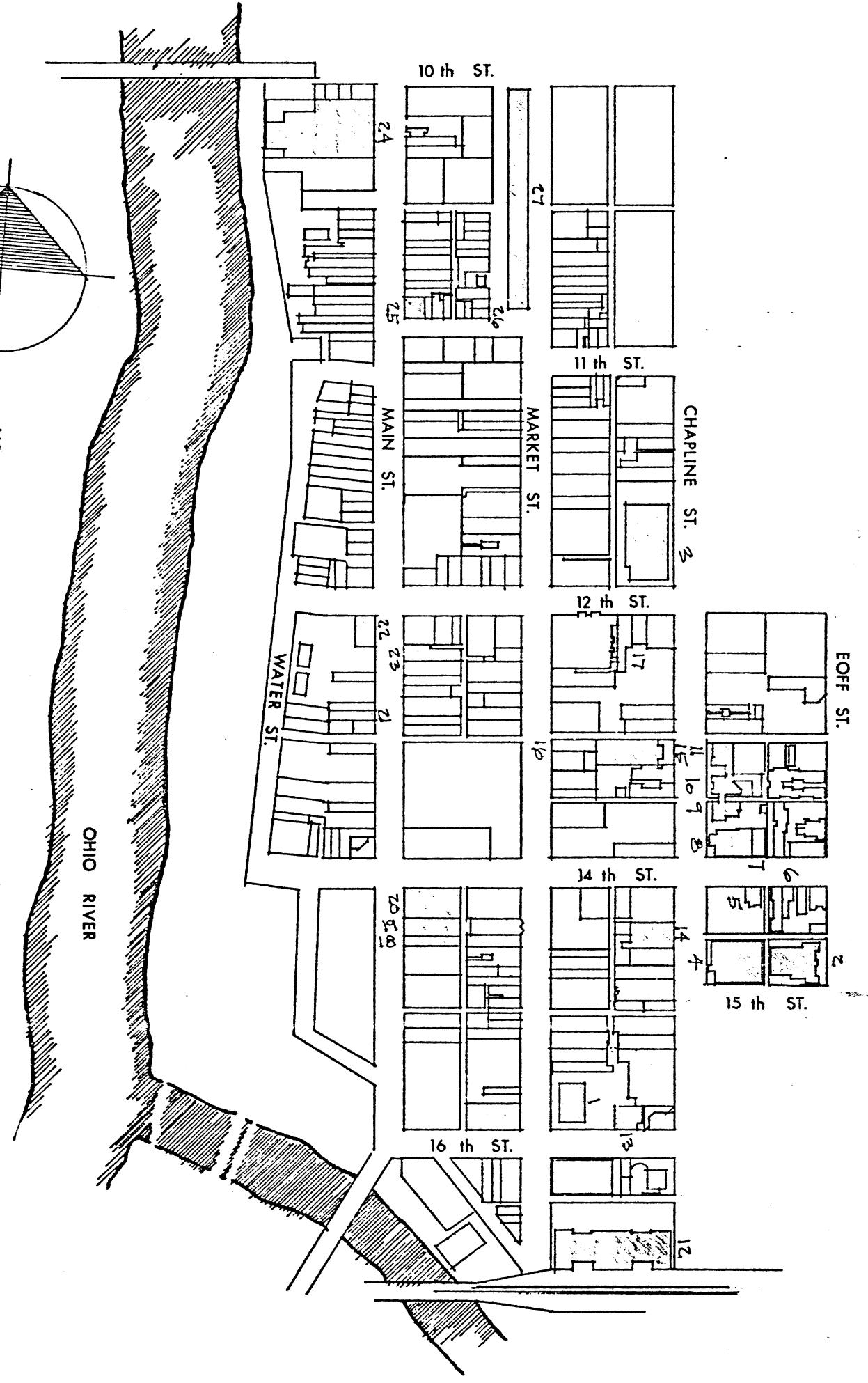
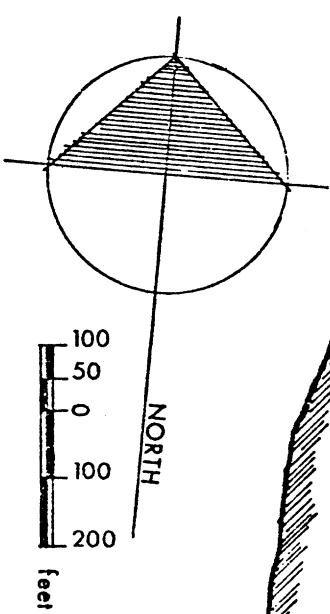

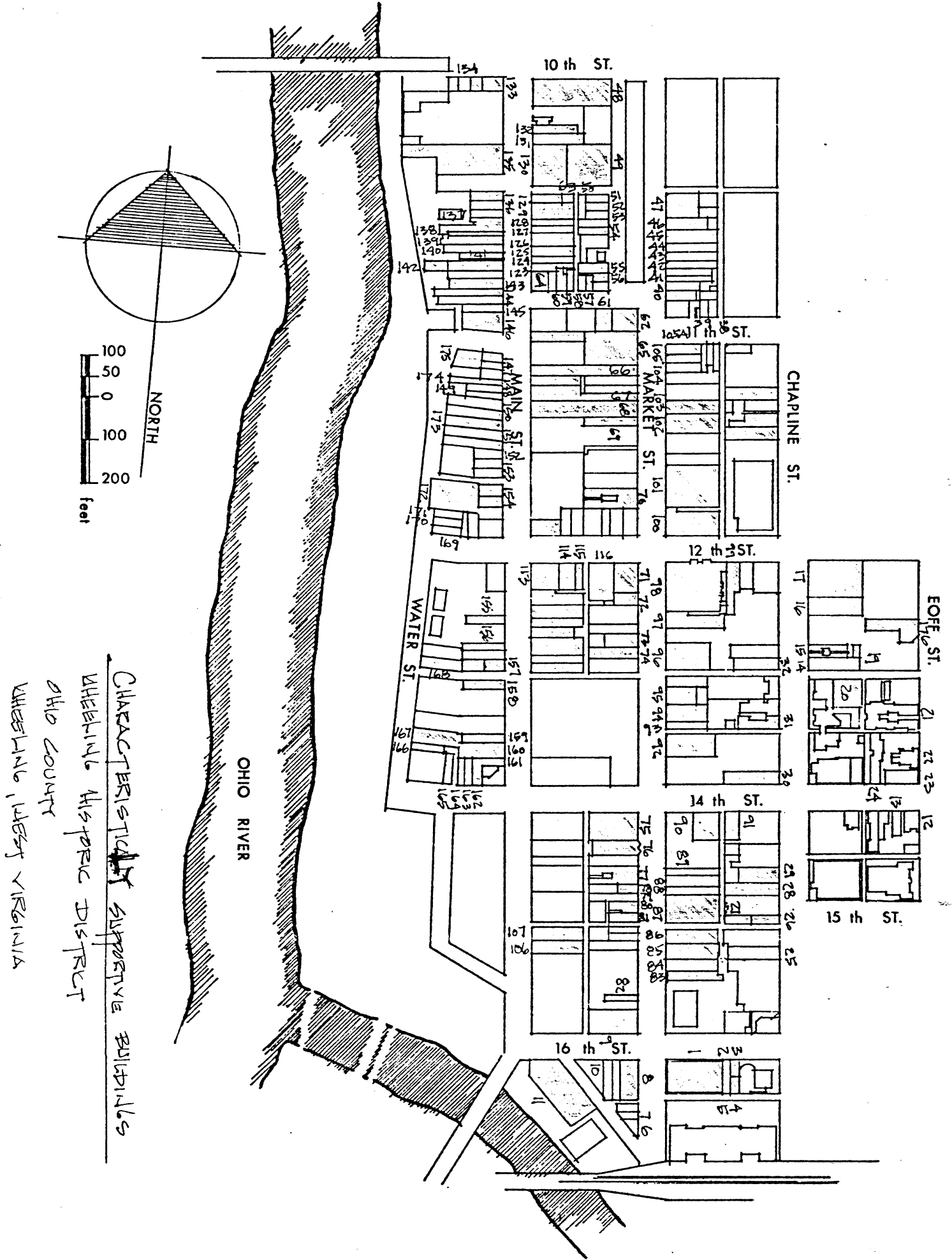

CHARACTERISTIC SUPPORTIVE BUILDINGS
 WHEELING HISTORIC DISTRICT
 OHIO COUNTY
 WEST VIRGINIA

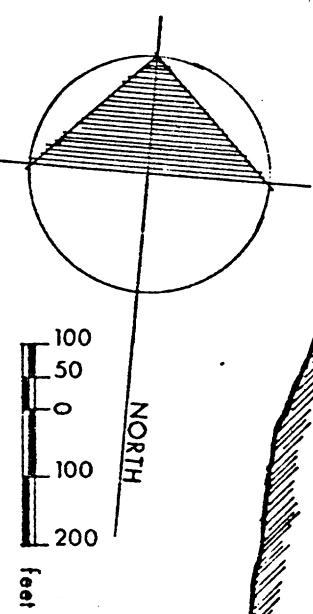
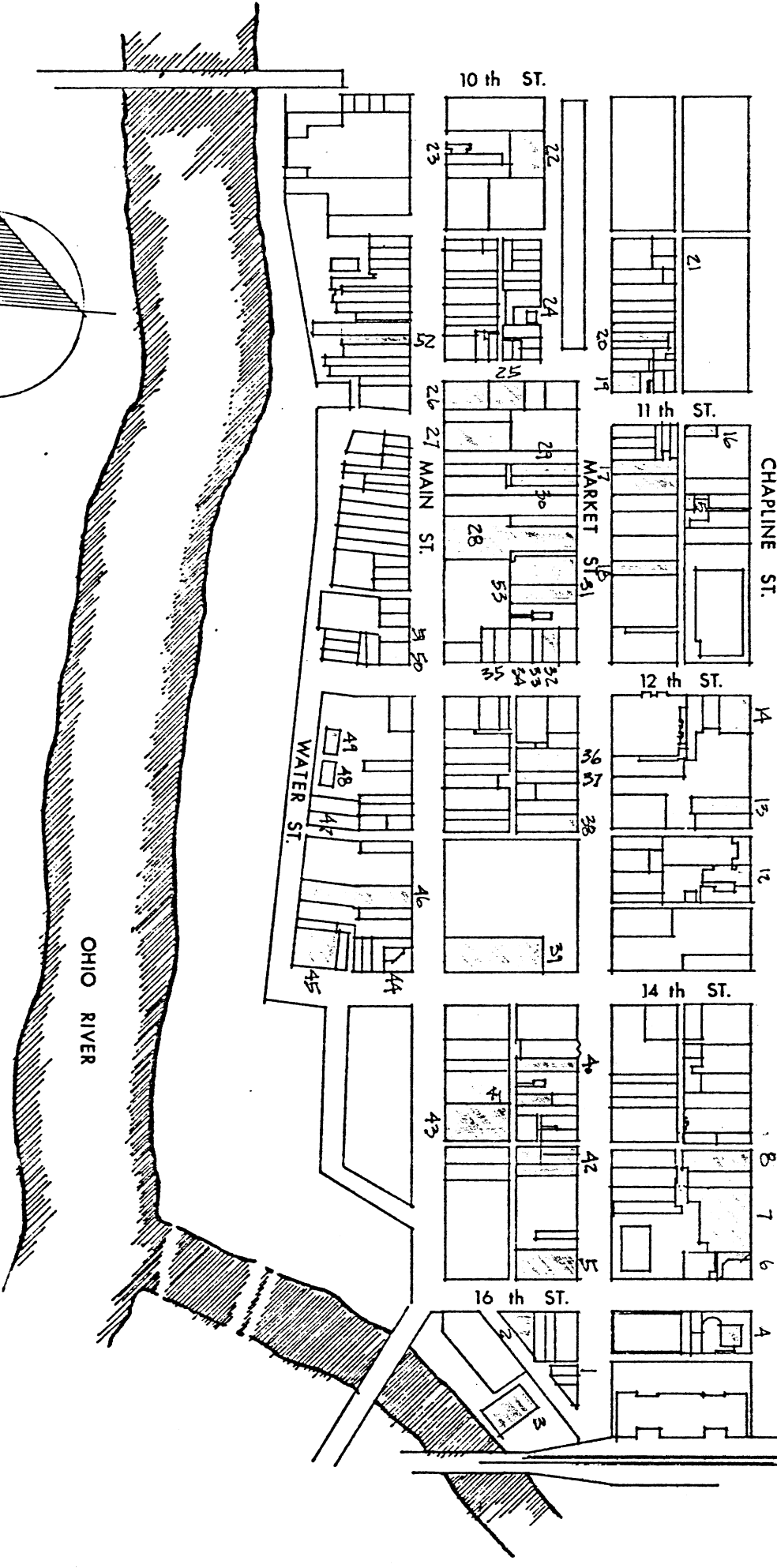
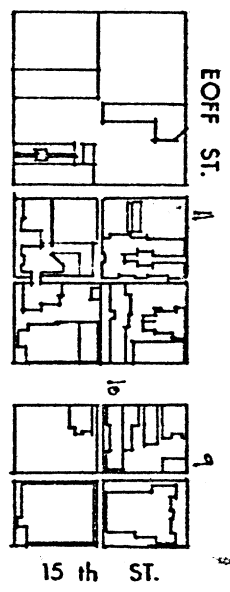

NON CONFORMING INTRUSIONS
 WHEELING HISTORIC DISTRICT
 OHIO COUNTY
 WHEELING, WEST VIRGINIA

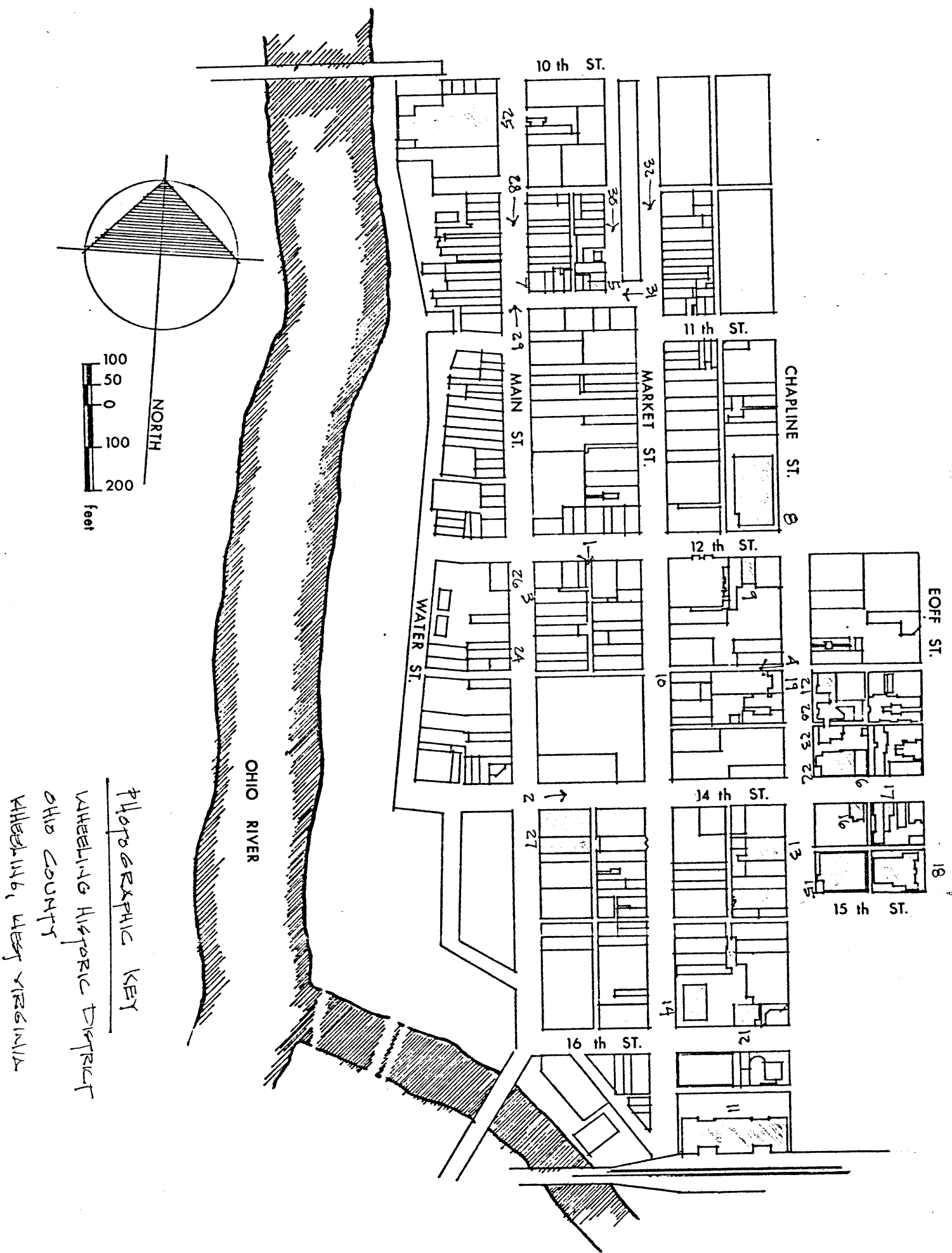

PHOTOGRAPHIC KEY

WHEELING HISTORIC DISTRICT
 OHIO COUNTY
 WHEELING, WEST VIRGINIA

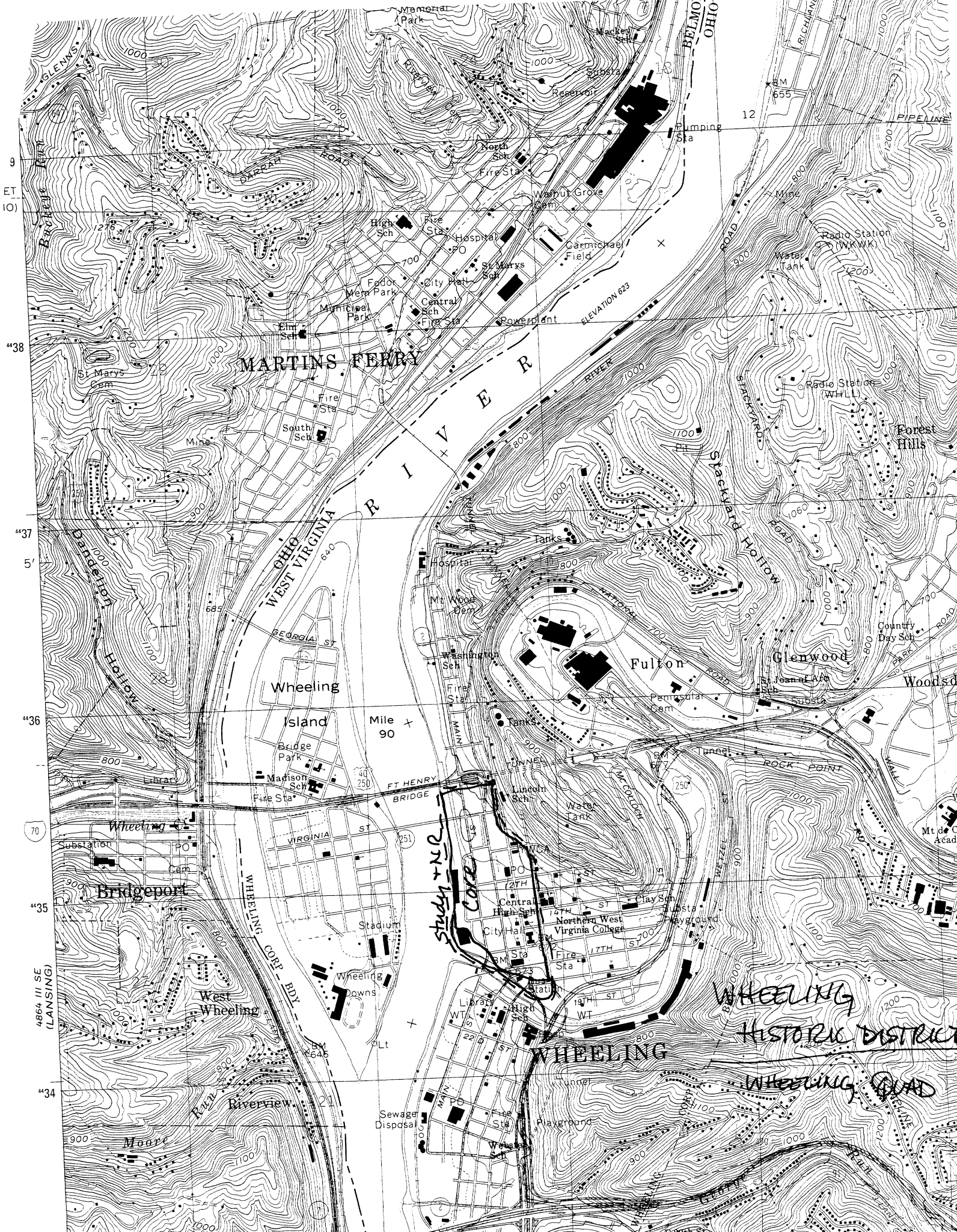

MARTINS FERRY

R I V E R

OHIO WEST VIRGINIA

Wheeling

Island

Bridgeport

West Wheeling

Riverview

FT HENRY BRIDGE

STUDY + MR

CARE

WHEELING

WHEELING

WHEELING HISTORIC DISTRICT

WHEELING QUAD

Fullon

Glenwood

Woods

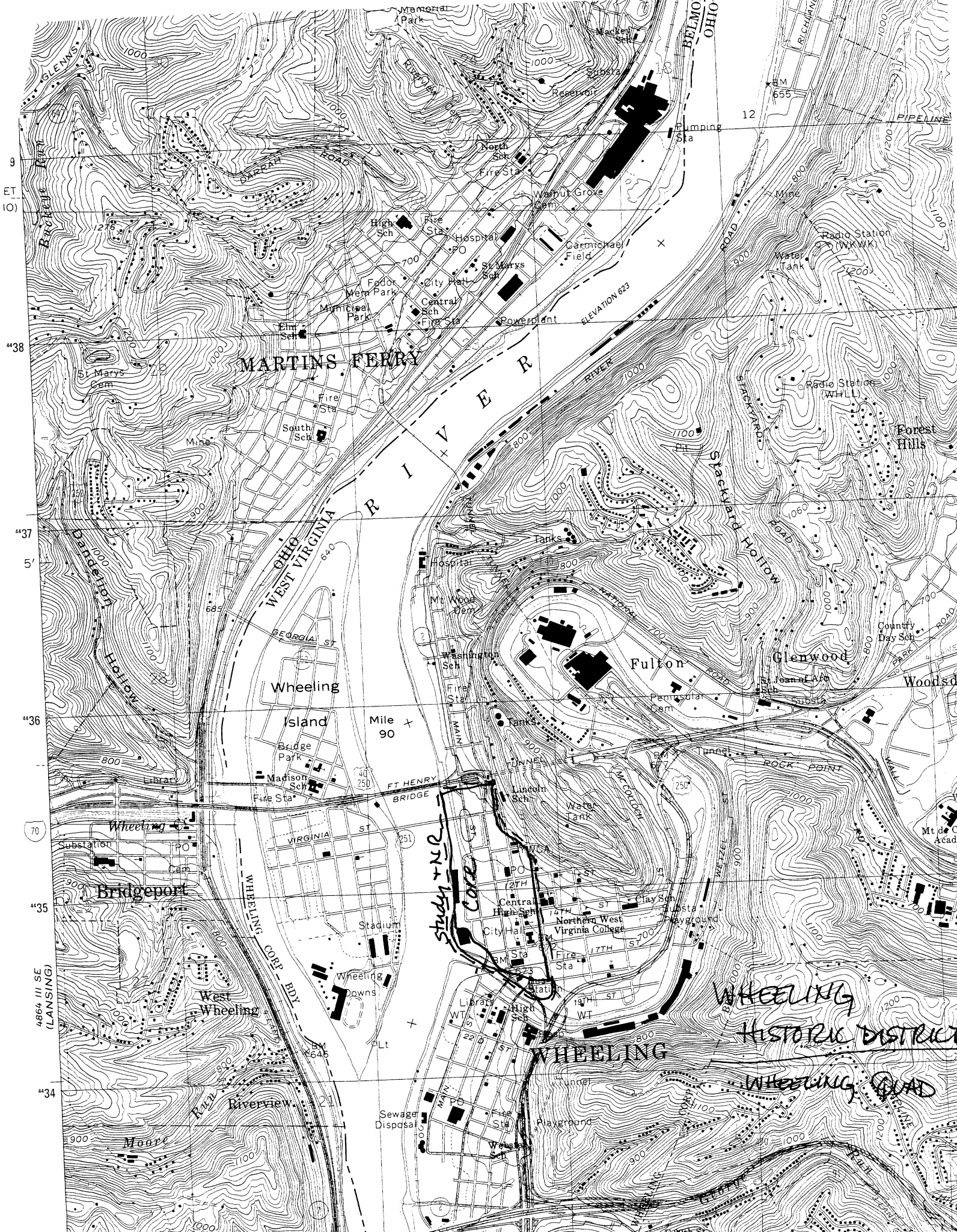











McGHEE & CO.
OFFICE SUPPLIERS
Wholesale Distributors
Business Records Forms
Duplicating Products
Business Equipment
Carbon Business Papers
Typing Supplies
116 MARKET ST.
P.O. #1
32-5440

McGHEE & CO.
OFFICE SUPPLIERS

McGHEE & CO.

WHEELING OFFICE SUPPLY
SUPPLIES OF
National LINES

OFFICE FURNITURE
Haller's
WHEELING OFFICE SUPPLY



